

TreeSonic

Microsecond Timer
User's guide



FAKOPP Enterprise Bt.
H-9423 Agfalva, Fenyo u. 26.
HUNGARY

www.fakopp.com

2006

Introduction

TreeSonic microsecond timer is designed for tree stiffness prediction, measures the stress wave time between start and stop transducer. The structure of TreeSonic tool is designed by Weyerhaeuser Co. The equipment is patent pending. Patent holder is Weyerhaeuser Co.

Preparation for the work

Connect the start sensor to the start connector of the timer. Please see the male and female connector first and use proper orientation while pushing the connector. Finally lock the connector by turning the metal part of the connector clockwise. At this step never touch the black plastic part of the connector. See figure 1.



*Figure 1. While connecting and disconnecting the transducers please touch the metal part only. This is very **IMPORTANT!** NEVER turn the plastic part of the connector.*

The longer and flat shape transducer is the start and the shorter and cube shape is the stop transducer. Please do not change the transducers.

Drive in the spike of the transducers into the tree you want to test using the sliding hammer. Spike need to penetrate through the bark and stabilize the transducer in the wood material. Please apply 45 degree as spike and fiber angle. See figure 2. Please do not bend the tip while inserting (straight in and avoid the knots) and extracting (straight and completely out) the probes.



Figure 2. Driving the start (left) and stop (right) transducers into the tree using sliding hammer

Instead of on/off switch

There is no on/off switch on the unit. For switching on please hit the start transducer, apply a relative strong hit by hammer. Hitting direction is always the axes of the transducer. Apply speedy hammer, let the hammer sping back. The firs reading is “9999” means that the switching on procedure is successful. The next hit will show the real transit time in microseconds. The unit switches of automatically

if no hit on start sensor arrives within 30 seconds. This function saves the battery.

The standard setup is shown on figure 3. The recommended distance between transducer is 1 meter. There is a 1 m mark on the start transducer cable.



Figure 3. The recommended setup.

Record the readout. Using the average of 3 readouts is recommended. The standard deviation of the readout is less than ± 1.5 microseconds.

Safety

The transducer has sharp spike. Please take care of the spike of the sensor, may injure yourself or person nearby you. When out of use please apply protector tube. Wearing safety shoes, safety glass and gloves is recommended. Fix upper (starter) probe properly, if probe would fall down, never catch while falling. In this case step back, and let it fall down.

Maintenance

After 10-12 hours operation time, batter goes down. A “BAT LOW” message appears on the screen. Your battery is rechargeable, capacity is 100 mAh. Figure 4. shows how to open the battery compartment.

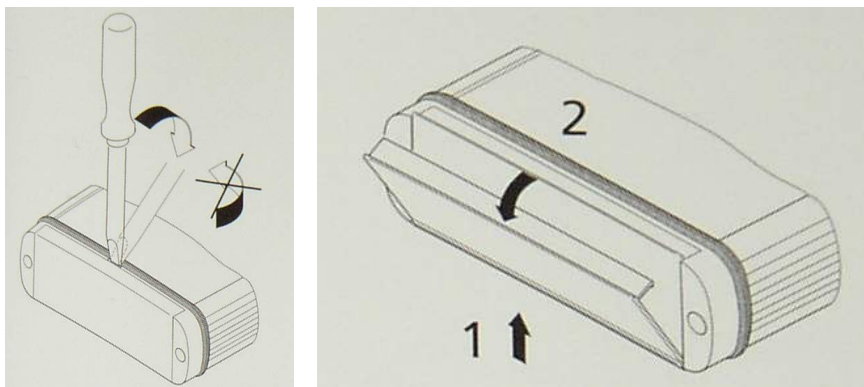

Figure 4. The door of the battery compartment can be open by screwdriver (left) or press the door in direction “1” while opening by hand. Change battery when the unit switched off automatically!

Guarantee:

For the TreeSonic device, including two sensors the guarantee is one year. The guarantee starts at the date displayed on the invoice and valid for the following one year. The repair can be asked from the manufacturer. The guarantee does not concern to the break or deliberate damage of the machine.

Technical parameters

Dimension of the timer: 36 x 84 x 184 mm

Weight: timer incl. battery: 0,35 kg

hammer incl. handle: 0,25 kg

Start transducer: 1,2 kg

Stop transducer: 1,1 kg

Total: 2,9 kg

Sleeping down time: 30 seconds

Time resolution: 1,2 microsecond

Battery: one piece of 9V block, rechargeable

Capacity: 100 mAh (typical)

Operation time: 10-12 hours

Power requirement: 75 mW

System is partly water resistant: IP65 protection

Determination of the time correction

date: July 20, 2006

equipment: TreeSonic, serial no.: TS-

conditions: distance between transducers:20 - 100 cm, material: spruce

intercept of distance - read out line determines the time correction

distance [cm]	average					
	read out [μ s]					
100	230,0	230	230	230	230	230
79	177,2	178	178	176	178	176
59	133,0	133	133	133	133	133
40	90,6	91	91	90	91	90
19,5	47,0	47	47	47	47	47

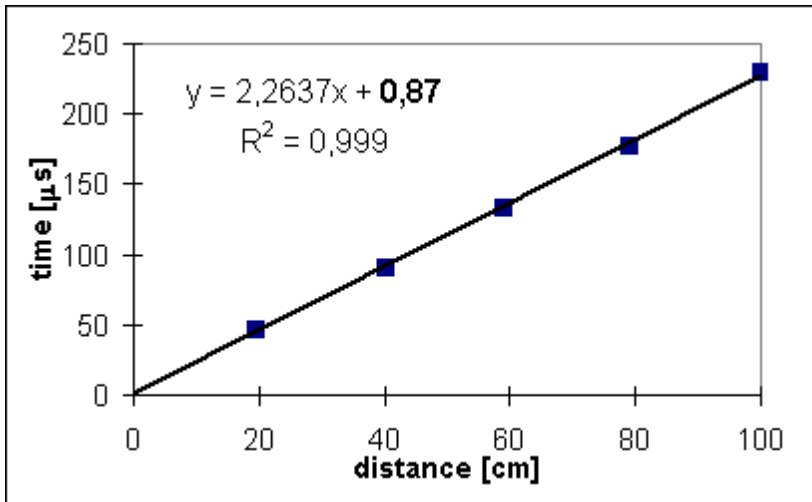

Time correction is 0,9 μ s

Velocity determination:

$$V[m/s]=1000*distance[mm] / (FAKOPP read out[\mu s]+0,9)$$

Remark:

- penetration depth at starter and receiver was 50mm
- 10 mm change in spike penetration depth results
5 μ s change in transit time. (less penetration -> higher time)
- mass of the hammer: 200g

